



## ROUND METAL CEILING LOUDSPEAKERS

# RCS5FT/EN



The RCS range of ceiling loudspeakers have been carefully designed to blend seamlessly in to any installation. These units are stylish yet unobtrusive.

Made from a pressed steel epoxy coated chassis incorporating a twin cone driver, which offers a wider frequency response than a standard single cone, this gives the RCS range a superior performance. Designed to make installation quick and easy and suitable for use in applications where background music and speech are the primary requirement such as shops, schools, restaurants, hotels, public houses, offices etc.



### EN54-24:2008 0905-CPR-201110 TYPE A

● <b>Standard</b>	Compliant to EN54-24 Compliant to BS5839:8
● <b>Electrical</b>	
Maximum power, Watts	9
Rated power, Watts	6
Tappings 100 volt line, Watts	6/3/1.5/0.75/0.25
Transformer Impedance, Ohms 100V	1.67k/3.33k/6.66k/13.3k/40k
Tappings 70.7 volt line, Watts	3/1.5/0.75/0.375/0.125
Driver impedance, Ohms	8
Effective Frequency Range, Hz (BSEN60268-5)	150 - 18,000
S.P.L. @ 1 m, 1 Watt, dB, Octave, 100 Hz-10 kHz	94
S.P.L. @ 1 m, Full power, dB, Octave, 100 Hz-10 kHz	102
S.P.L. @ 4 m, 1 Watt, dB, 1/3 Octave, 100 Hz-10 kHz	81
S.P.L. @ 4 m, Full power, dB, 1/3 Octave, 100 Hz-10 kHz	85
Dispersion at 1k/2k Hz, Degrees	177/93 Horizontal 176/118 Vertical
● <b>Environmental</b>	
IP Rating	21
Min/Max amb temp	-10°C to 55°C
Relative Humidity	≤95%
● <b>Mechanical</b>	
Dimensions, mm	Ø189 x 115.7
Net weight, kg	1.3
Colour (Unless Specified)	White, RAL9016
Material	Steel
Mounting	Torsion Springs
Cut-out, mm	Ø164



**ATEIS Europe B.V.**  
Celsiusstraat 1, 2652 XN Lansingerland, Netherlands  
Phone +31 (0)10 208 86 90, [www.ateis-europe.com](http://www.ateis-europe.com), [info.eu@ateis.global](mailto:info.eu@ateis.global)



# INSTALLATION GUIDE

## RCS5FT/EN

EN54-24:2008  
0905-CPR-201110  
TYPE A

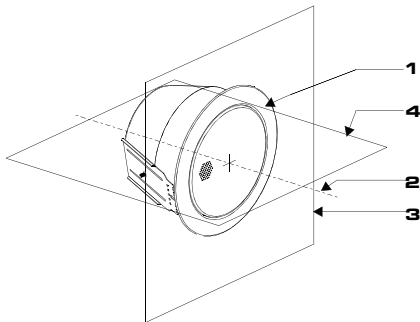
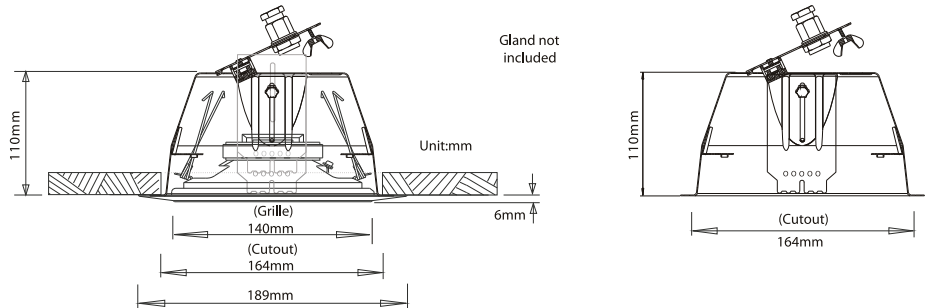

1. Loudspeaker enclosure
2. Reference axis
3. Reference plane
4. Horizontal plane

**With Transformer:  
100V/70V line**

	White wire plus tapping					Black
100V	0.25W	0.75W	1.5W	3W	6W	COM
70V	0.125W	0.375W	0.75W	1.5W	3W	COM
IMP ( $\Omega$ )	39.9K	13.3K	6.66K	3.33K	1.67K	

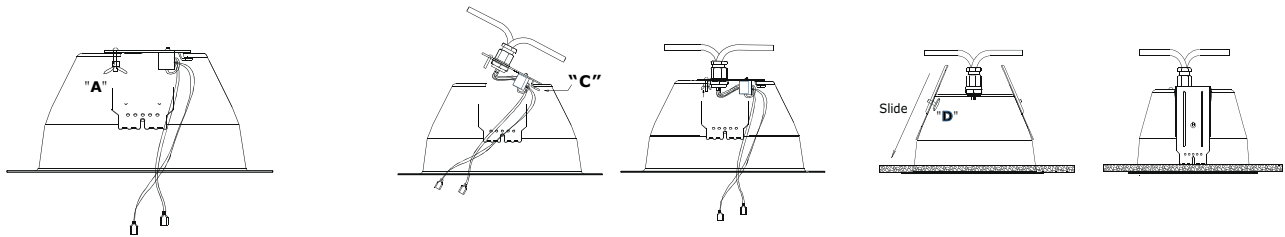

1) Remove the wing nut "A" located on the inside of the fire dome.

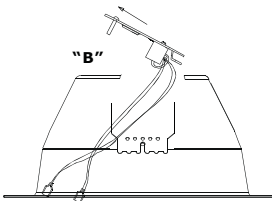

2) Lift the termination plate upwards & away to separate it from the fire dome "B".

3) Gland the installation cable into the termination plate using suitably rated 20 mm glands. 2 gland entries are provided for "loop in" "loop out" termination if required.

4) Terminate the installation cable into the terminal block on the underside of the termination plate "C".

5) Fix the termination plate back into the fire dome and secure using the wing nut previously removed. Do not over tighten to avoid damaging the thread.

### FITTING THE DOME INTO A CEILING

6) Cut a 164 mm diameter hole paying attention to ensure that the cut-out is accurately made. As if it is not, the speaker may not fit correctly into the ceiling preventing the speaker from sitting flush to the surface.

7) Loosen the slider knob "D", push the knob & plate upwards to the top of the fire dome and re-tighten the knob to hold the slider in place. Repeat the same process with the other slider.

8) Push the complete fire dome into the cut-out.

9) Once in place loosen the slider knob "D", push the knob & plate downwards until the slider makes firm contact with the ceiling. Tighten the knob to secure it into place. Repeat the same process with the other slider.



# INSTALLATION GUIDE

## RCS5FT/EN

EN54-24:2008  
0905-CPR-201110  
TYPE A

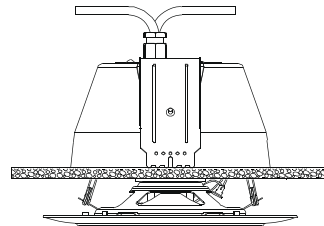
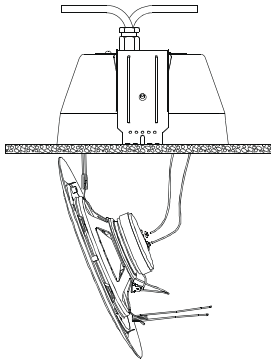

**10)** The fire dome should be firmly secured into the ceiling.

**11)** Take the speaker and compress one of the mounting springs & place both ends of the spring into one of the retaining brackets located on the inside wall of the fire dome. Release the spring slowly into the bracket. Once fully released the spring will hold one side of the speaker into the fire dome.

**12)** With the speaker in this position connect the 3 wires hanging from the termination plate on to the speaker using the spade terminals provided.

**13)** Fit the second spring mount on the speaker to the remaining bracket on the inside of the fire dome. Finally push the speaker into position.

**14)** If fitted correctly the speaker should fit flush to the surface.

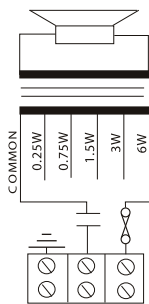

**Circuit Diagram**

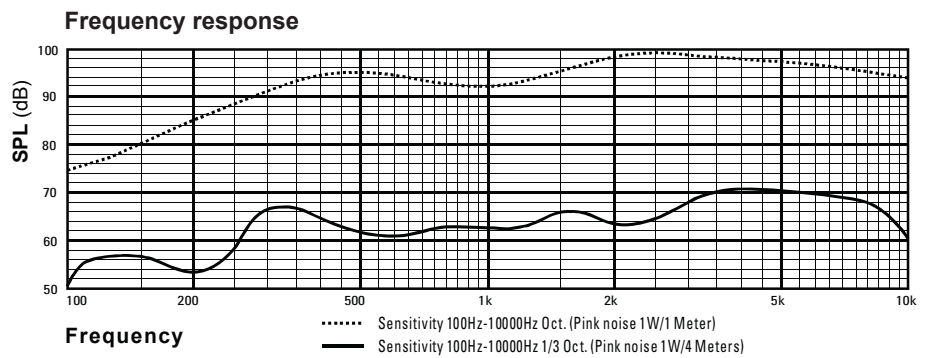

Disclaimer: We reserve the right of changes and errors.



**ATEIS Europe B.V.**  
Celsiusstraat 1, 2652 XN Lansingerland, Netherlands  
Phone +31 (0)10 208 86 90, [www.ateis-europe.com](http://www.ateis-europe.com), [info.eu@ateis.global](mailto:info.eu@ateis.global)

